

6. Gateway

6.1 HA-MA164AD



MRV	LCAC			
	Smart Power	Super Match	R410A ON/OFF	R22 ON/OFF
√				

Model No.		HA-MA164AD	
No. of IU Controllable	For Centralized controller	64	
	For BMS system	40	
	For third party devices	64	
	For Lonworks (IGU07)	64	
Protocol	Central control protocol	√	
	MRV protocol	√	
	Modbus rtu	√	
	For Lonworks (IGU07)	√	
Compatible Control devices	Centralized controller	Y CZ-G001,A004	√
	Haier BMS system	HCM-01A,03,05,05A	√
	Third party devices	IGU07,HA-AC-KNX	√
Power Consumption			
Installation Method		Outside the OU	
Compatible OU Type		Side and Top discharge OU; MRV W	

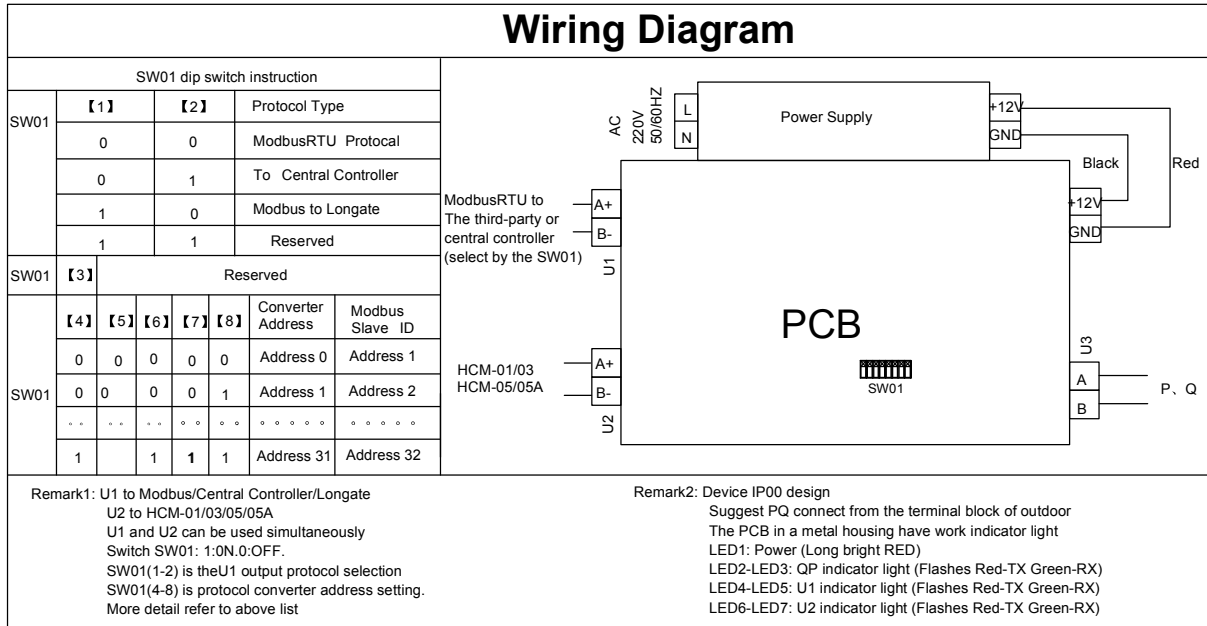

Modbus point list

Default properties:

Bits per second:9600 Data bits:8

Parity: None Stop bits:1

1.Discrete Inputs--0x02

REGISTER ADDRESS	POINT NAME	EXPLANATION
0000	INDOOR1 EXIST OR NOT	READ ONLY 1-EXIST, 0- NOT EXIST
0001	INDOOR1 ON LINE OR NOT	READ ONLY 1-ON LINE,0-OFF LINE
0002	INDOOR2 EXIST OR NOT	READ ONLY 1-EXIST, 0- NOT EXIST
0003	INDOOR2 ON LINE OR NOT	READ ONLY 1-ON LINE,0-OFF LINE
.....		
00126	INDOOR64 EXIST OR NOT	READ ONLY 1-EXIST, 0- NOT EXIST
00127	INDOOR64 ON LINE OR NOT	READ ONLY 1-ON LINE,0-OFF LINE

2.Coil-Ox01

REGISTER ADDRESS	POINT NAME	EXPLANATION
0000	INDOOR1 ON/OFF	READ/WRITE 1-ON,0-OFF
0001	INDOOR2 ON/OFF	READ/WRITE 1-ON,0-OFF
0002	INDOOR3 ON/OFF	READ/WRITE 1-ON,0-OFF
0003	INDOOR4 ON/OFF	READ/WRITE 1-ON,0-OFF
.....		
00062	INDOOR62 ON/OFF	READ/WRITE 1-ON,0-OFF
00063	INDOOR64 ON/OFF	READ/WRITE 1-ON,0-OFF

Input Register--0x04(READ ONLY)

REGISTER ADDRESS	POINT NAME	RANGE	UNIT
0	INDOOR1 AMBIENT TEMP	-30 --60	1°C
1	INDOOR1 ERROR CODE	0-256	0-NORMAL
2	INDOOR1 HP	0-150	0.1HP
3	INDOOR2 AMBIENT TEMP	-30 --60	1°C
4	INDOOR2 ERROR CODE	0-256	0-NORMAL
5	INDOOR2 HP	0-150	0.1HP
.....			
189	INDOOR64 AMBIENT TEMP	-30 --60	
190	INDOOR64 ERROR CODE	0-256	0-NORMAL
191	INDOOR64 HP	0-150	0.1HP

3.Holding Register-0x03

REGISTER ADDRESS	POINT NAME	UNIT	RANGE	REMARK
0	INDOOR1 SET TEMP	°C	16-30	READ/WRITE
1	INDOOR1 RUNNING MODE		1-5	READ/WRITE 1-COOL 2-HEAT 3-DRY 4-FAN 5-AUTO
2	INDOOR1 FAN SPEED		1-4	READ/WRITE 1-LOW, 2-MID, 3-HIG 4-AUTO
3	INDOOR1 CONTROL MODE		1-4	READ/WRITE 1 -NORMAL,2-LAST IN FIRST OUT, 3-CENTRAL CONTROL, 4-LOCK
.....				
252	INDOOR64 SET TEMP	°C	16-30	READ/WRITE
253	INDOOR64 RUNNING MODE		1-5	READ/WRITE 1-COOL 2-HEAT 3-DRY 4-FAN 5-AUTO
254	INDOOR64 FAN SPEED		1-4	READ/WRITE 1-LOW, 2-MID, 3-HIG 4-AUTO
255	INDOOR64 CONTROL MODE		1-4	READ/WRITE 1 -NORMAL,2-LAST IN FIRST OUT, 3-CENTRAL CONTROL, 4-LOCK
256	OUTDOOR STATUS			1-MALFUNCTION, 0-NORMAL